

# FreqCnt logic board

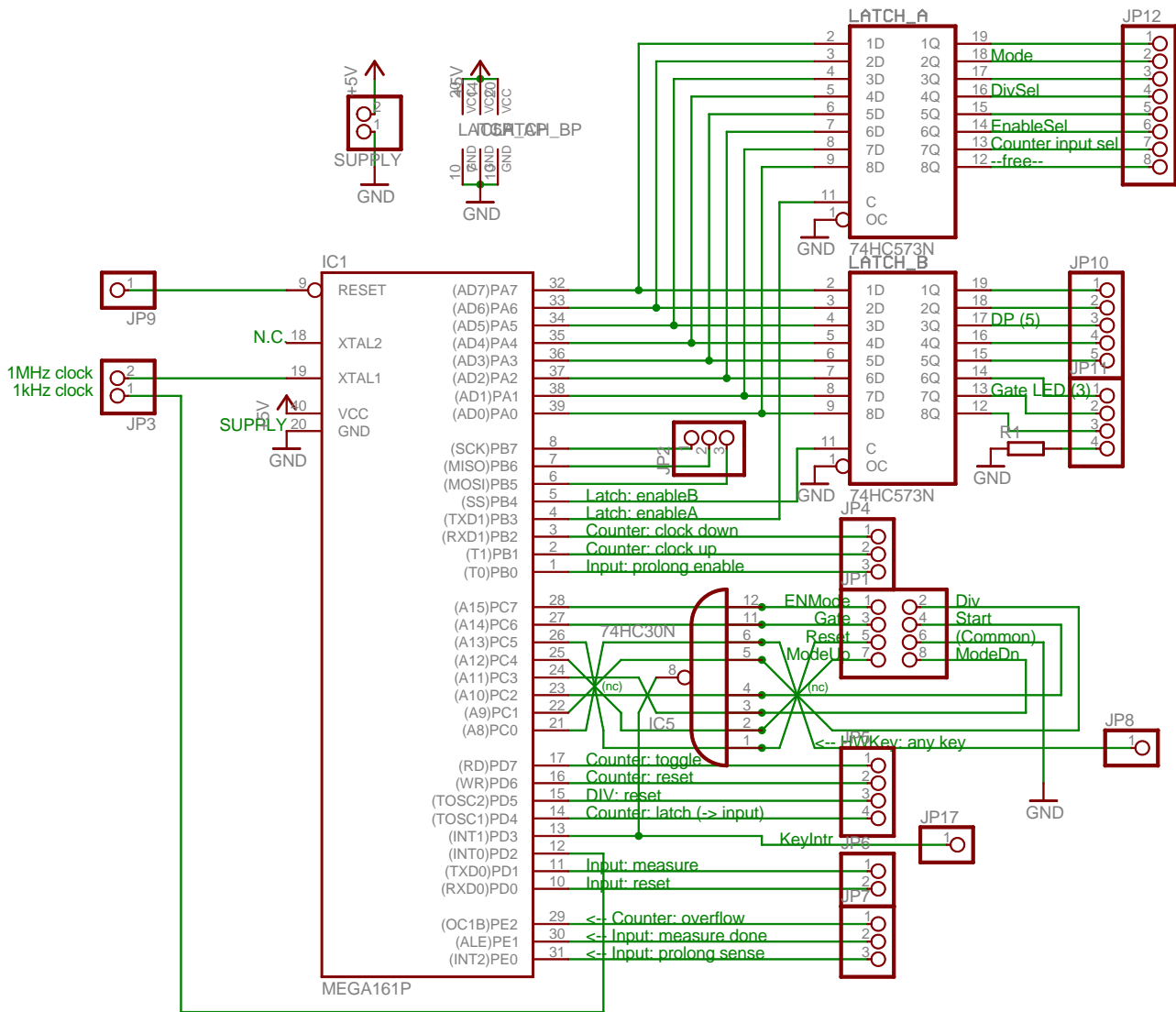

# FreqCnt 5V supply circuit

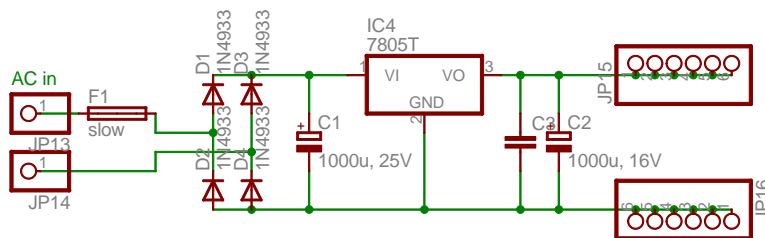

FreqCnt logic and supply  
(c) 04/2004 by Wolfgang Wieser

TITLE: logic-rev2

Document Number:

REV:  
2

Date: 4/25/2004 14:59:04

Sheet: 1/1